

# BAUHN®

## Portable Party Speaker

MODEL: APPS-0423

## User Manual



AFTER SALES SUPPORT

  1300 002 534

 [tempo.org/support](https://tempo.org/support)

MODEL: APPS-0423 PRODUCT CODE: 710656 04/2023



# Welcome

Congratulations on your purchase!

This manual tells you all you need to know about using your new BAUHN® product.

Please take special note of any important safety and usage information presented with the  symbol.

All products brought to you by BAUHN® are manufactured to the highest standards of performance and safety and, as part of our philosophy of customer service and satisfaction, are backed by our comprehensive 1 Year Warranty.

Domestic use only: This product is intended for indoor domestic use only. Do not use this product for anything other than its intended purpose, and only use it as described in this manual.

We hope you will enjoy using your purchase for many years to come.

# Contents

Welcome	2
Unpack and Prepare	4
Product Overview	5
Remote Control	7
Wireless Microphone	9
Operation	10
Troubleshooting	14
Specifications	16
Compliance and Responsible Disposal	17
Warranty Information	18
Repair and Refurbished Goods or Parts Notice	19

# Unpack and Prepare

## What's in the box

Before setting up your new product, check you have everything:

- A. Portable Party Speaker
- B. Remote Control
- C. AAA Activ Energy Batteries (2)
- D. Wireless Microphone
- E. AA Activ Energy Batteries (2)
- F. AC Power Cable
- G. AC Power Adaptor
- H. Warranty Certificate
- I. General Safety Warnings
- J. User Manual

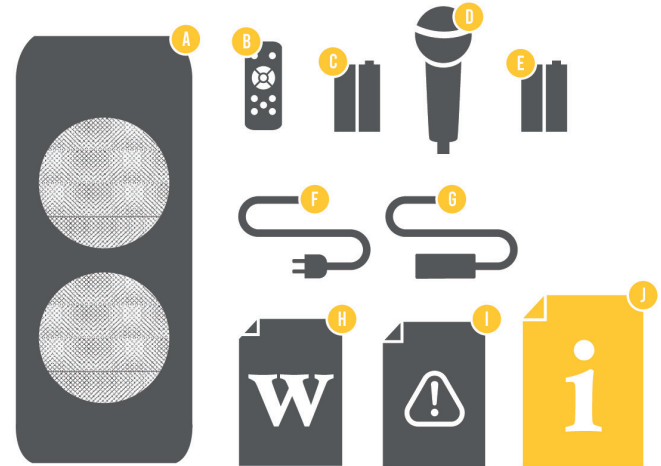

# Product Overview

## Speaker Overview

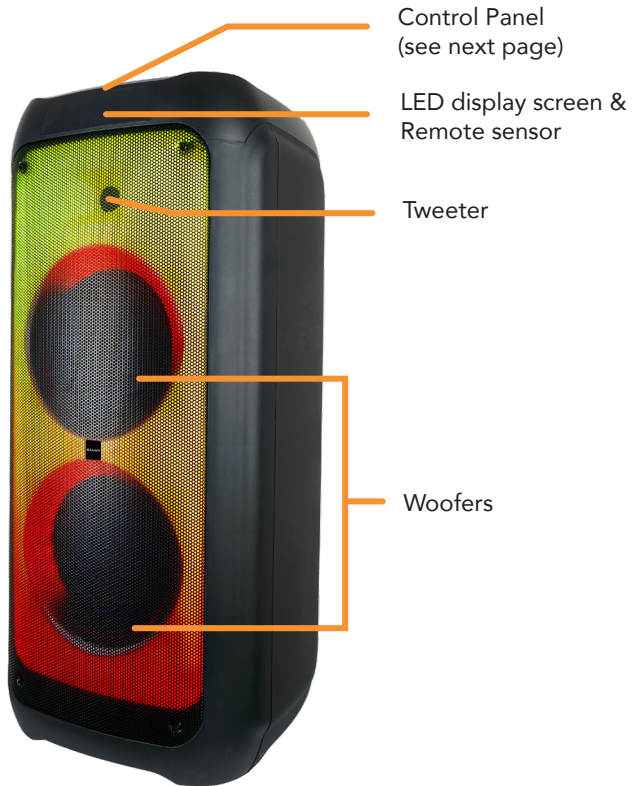

See the next page for the  
control panel buttons

# Control Panel

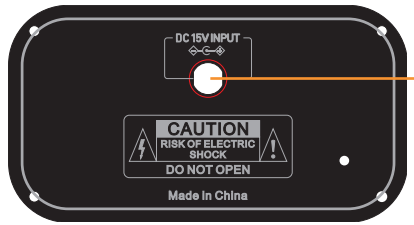
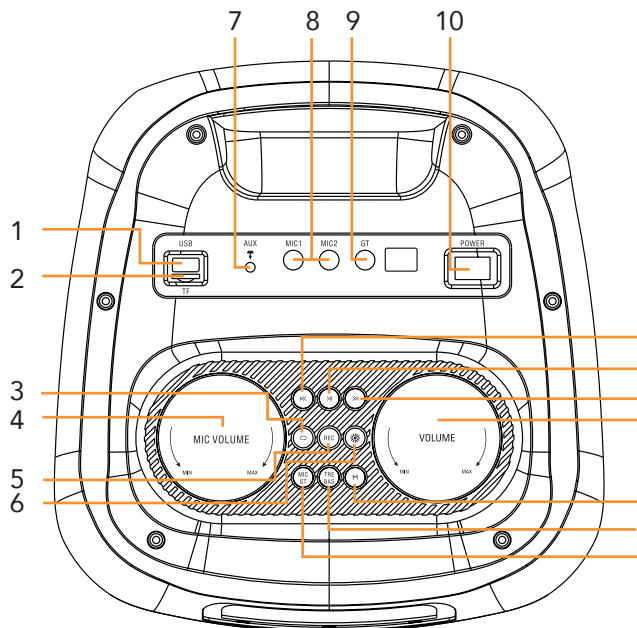

Rear Panel

- 1 USB Slot: insert your USB for music playback
- 2 Micro SD (TF) Card Slot : insert Micro SD/TF card for music playback
- 3 (Repeat): repeat current song
- 4 Mic Volume Knob: adjust microphone or guitar volume
- 5 REC: to record voice recordings to USB/Micro SD card
- 6 LIGHT SW (☀): press to change the speaker light effect  
Press repeatedly to change between light effects/turn light effect off. (Note: this effect does not work when on FM mode)
- 7 AUX In Port
- 8 MIC 1/MIC 2: input for wired microphones (not included)
- 9 GUITAR (GT): input for guitar (not included)
- 10 Power switch: press to turn speaker on/off
- 11 : play previous song
- 12 : play/pause song
- 13 : play next song
- 14 Volume Knob: adjust volume level
- 15 MODE (M): press to switch between USB, Micro SD, AUX, FM and Bluetooth® mode
- 16 TREBLE/BASS: press to select treble/bass and turn the volume knob to adjust level. Press and hold to turn mega bass on/off
- 17 MIC GT: press to adjust microphone or guitar volume
- 18 DC IN Port

# Remote Control

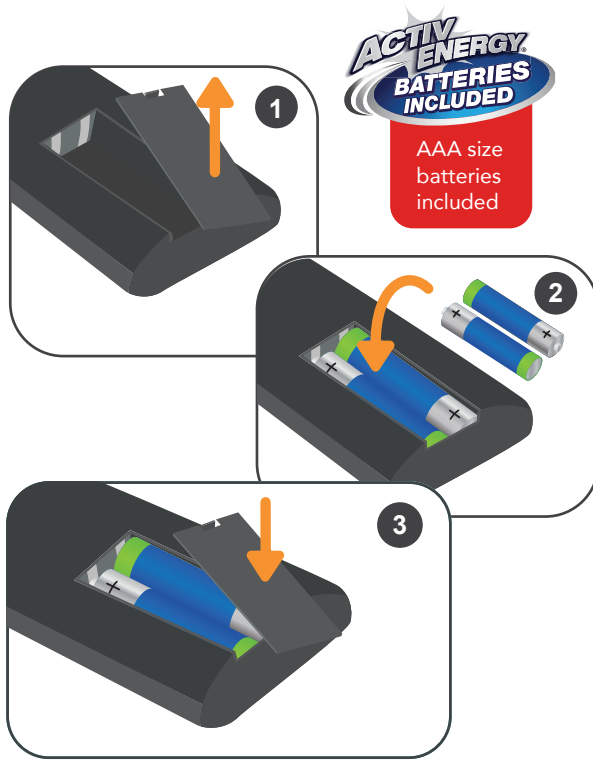

## Setup

Insert the supplied AAA Activ Energy Batteries according to the polarity markings (+ / -) inside the compartment. Make sure the batteries are correctly aligned and properly pushed into place.



### Precautions When Using Batteries

- Do not use old and new batteries together.
- Do not use different types of batteries (e.g. Manganese and Alkaline batteries) together.
- Remove the batteries from the remote if you do not intend to use it for a long time.
- When discarding used batteries, follow any guidelines for recycling and disposal of batteries that apply in your local area.
- Keep batteries away from children and pets.
- Never throw batteries into a fire or expose them to extreme heat.

# Remote Overview

**MUTE** : Mute the sound. Press again to unmute

**NUMBER BUTTONS** : Numerical input to directly play a track.

**ECHO+** : Press to increase echo level

**ECHO-** : Press to decrease echo level

**EQ** : Change EQ mode

**◀◀** : Select previous song/previous FM station

**TREBLE-** : Press to decrease treble level

**M.VOL +** : Increase microphone volume level

**VOLUME -** : Decrease volume level

**BASS-** : Decrease bass level

**M.TRE-** : Decrease microphone treble level

**M.TRE+** : Increase microphone treble level

**MIC.PRI** : Turn microphone priority on

**REPEAT** : Repeat song



**MODE** : Press to switch between input modes

**GT.VOL+** : Press to increase guitar volume level

**GT.VOL-** : Press to decrease guitar volume level

**▶▶** : Select next song/next FM station

**⏸** : Play/pause, auto scan FM stations

**TREBLE+** : Press to increase treble level

**VOLUME +** : Increase volume level

**LIGHT SW** : Press to change the speaker light effect. Press repeatedly to change between light effects/turn light effect off

**M.VOL -** : Decrease microphone volume level

**BASS+** : Increase bass level

**M.BASS+** : Increase microphone bass level

**M.BASS-** : Decrease microphone bass level

**FOLDER** : Select between folders if USB/ Micro SD card have folders

**REC** : Start recording



# Wireless Microphone

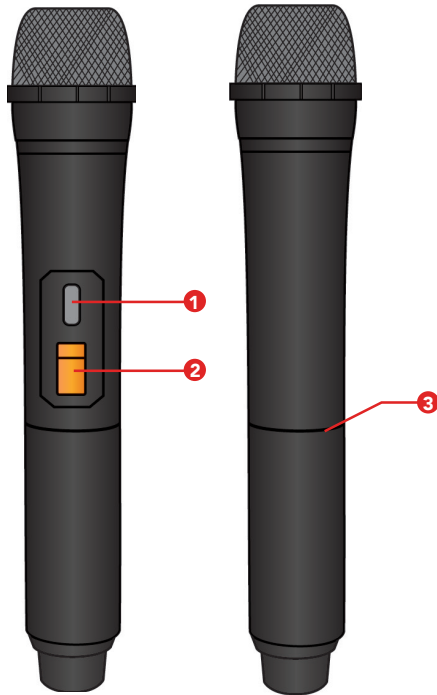

- 1 Battery indicator (red LED when mic is on)
- 2 On/Off switch
- 3 Battery cover (twist to open)

## Setup

Insert the supplied AA Activ Energy Batteries according to the polarity markings (+ / -) inside the compartment. Make sure the batteries are correctly aligned and properly pushed into place.



## Precautions When Using Batteries

- Do not use old and new batteries together.
- Do not use different types of batteries (e.g. Manganese and Alkaline batteries) together.
- Remove the batteries from the microphone if you do not intend to use it for a long time.
- When discarding used batteries, follow any guidelines for recycling and disposal of batteries that apply in your local area.
- Keep batteries away from children and pets.
- Never throw batteries into a fire or expose them to extreme heat.

# Operation

## Charging and Power on

- Charging: plug in the supplied power adaptor to the DC IN port to charge the speaker for 6-7 hours before use. During charging, the battery icon on the LED display screen will flash. Please disconnect and unplug the power adaptor after charging.
- Power on: press the POWER switch on the speaker to turn the speaker on.

## Control Panel Operations

- Use the ◀ / ▶ buttons on the speaker or the PREVIOUS/NEXT buttons on the remote control to navigate between songs/FM stations.
- Use the volume knob on the speaker or the VOLUME-/VOLUME+ buttons on the remote control to adjust the volume.
- Use the MODE button to switch between the input modes. The LED display screen will show the current input mode the speaker is on.

## Battery Status

- You can view the battery status of the speaker on the LED display screen. When the battery is low, a voice notification will be heard. Please plug in the supplied power adaptor to charge the speaker.

## LED Light

- The speakers have LED lights across the front of the speaker. Press the LIGHT EFFECT button on the speaker or Light SW button on the remote control to turn the lights on/off. (Note: this effect does not work when on FM mode).

## Bluetooth® Mode

- Press the MODE button on the speaker until Bluetooth® is selected; "bLUE" will flash on the LED display screen and you will hear "Bluetooth mode."
- On your smart phone, search for "BAUHN APPS-0423." If a password is required, enter "0000". If pairing is successful, the LED display screen on the speaker will display "bLUE". You will also hear "Bluetooth connected." You can now play music from your smart phone.
- Press the >|| button on the speaker or the PAUSE/PLAY button on the remote control to play/pause music.
- Press the << / >> buttons on the speaker or PREVIOUS/NEXT buttons on the remote to select the previous or next track.
- Use the volume knob on the speaker or the VOLUME-/VOLUME+ buttons on the remote control to adjust volume level.
- Alternatively, you can control music playback from your smart phone.
- Press and hold the PAUSE/PLAY button on the remote for 3 seconds to disconnect existing paired device.
- After disconnecting Bluetooth® connection, "bLUE" will flash on the LED display screen.
- Note: only one playback unit can be connected to the speaker. If the speaker is already connected to another playback unit, the speaker will not appear in the Bluetooth® selection list. To disconnect the existing paired device, press and hold the PAUSE/PLAY button on the remote for 3 seconds.

## AUX Mode

- Use an audio cable (not included) to connect your external device through the AUX port on the speaker. Press the MODE button to change the AUX mode.
- Use the volume knob on the speaker or the VOLUME-/VOLUME+ buttons on the remote control to adjust volume level.
- Note: to play/pause, play previous or next tracks, please control from your external device.

## USB Mode

- Insert your USB device into the USB slot on the speaker. The speaker will automatically play the files.
- Press the >|| button on the speaker or PAUSE/PLAY button on the remote control to play/pause music.
- Press the << / >> buttons on the speaker or the PREVIOUS/NEXT buttons on the remote to select the previous or next track. .
- Use the volume knob on the speaker or the VOLUME-/VOLUME+ buttons on the remote control to adjust volume level.
- Note: If a USB device is not inserted in the speaker, USB mode will not be available.

## Micro SD Card Mode

- Insert your Micro SD (TF) card into the MICRO SD CARD slot on the speaker. The speaker will automatically play the files.
- Press the >|| button on the speaker or the PAUSE/PLAY button on the remote control to play/pause music.
- Press the << / >>| buttons on the speaker or the PREVIOUS/NEXT buttons on the remote to select the previous or next track.
- Use the volume knob on the speaker or the VOLUME-/VOLUME+ buttons on the remote control to adjust volume level.
- Note: If a Micro SD (TF) card is not inserted in the speaker, Micro SD Card mode will not be available.



- Note: please insert your Micro SD (TF) card into the MICRO SD CARD slot on the speaker as illustrated.

## Recording

- Plug in your USB device or Micro SD (TF) card into the USB/Micro SD card slot on the speaker. The speaker will automatically play the files.
- Plug in a wired microphone (not included) into the MIC 1 port on the speaker. Test the microphone and ensure your voice is audible from the speaker.
- Press the REC button on the remote control to start your recording. Press and hold the button again to stop recording.
- The speaker will automatically play the saved recording. Press the >|| button (speaker) or PAUSE/PLAY button (remote) to pause playback.
- Note: the recording function can only record your voice.

## Microphone

- Plug in a wired microphone (not included) into the MIC 1 port of the speaker. Another wired microphone can be plugged into the MIC 2 port of the speaker if 2 microphones are desired.
- Press the M.VOL+/M.VOL- buttons on the remote control to adjust the volume level.
- Press the M.TRE+/M.TRE- buttons on the remote control to adjust the treble level.
- Press the MIC. PRI button on the speaker or remote control to turn microphone priority on/off. This function is off by default. Your vocals will overpower the background music. Press the button to turn off.
- After use, unplug the microphone and store away if not in use.

## Guitar

- Plug in a wired guitar (not included) into the GUIT port on the speaker.
- Press the GT.VOL+/GT.VOL- buttons on the remote control to adjust the volume level
- After use, unplug the guitar and store away if not in use.



# Troubleshooting

To keep the warranty valid, never try to repair the system yourself. If you encounter problems when using this unit, check the following points before requesting service.

Problem	Solution
No power	<ul style="list-style-type: none"><li>• Ensure that the battery is charged or the power adaptor is connected.</li></ul>
Remote control does not work	<ul style="list-style-type: none"><li>• Use the remote control closer to the speaker. Aim directly at the sensor on the front of the unit.</li><li>• Please check the battery is installed correctly.</li><li>• Replace the battery.</li></ul>
Echo function not working for wired microphone	<ul style="list-style-type: none"><li>• Check that the wired microphone is properly plugged into the Mic port of the speaker.</li><li>• Adjust the microphone echo volume by pressing the MIC button on the speaker.</li><li>• Note: echo function is not supported for guitar microphones.</li></ul>
Wired microphone/guitar not working	<ul style="list-style-type: none"><li>• Turn the MIC volume to max.</li><li>• Check that it is properly plugged into the MIC/GUITAR ports.</li></ul>
Distorted noise coming from microphone	<ul style="list-style-type: none"><li>• Have at least a 1metre between the microphone and speaker as having the microphone too close to the speaker will cause interference.</li><li>• Ensure that the microphone is not too close to the power source as having the microphone too closer to a power source will cause interference.</li></ul>
No response from the speaker	<ul style="list-style-type: none"><li>• Turn off the power switch and then turn on the switch.</li></ul>

Problem	Solution
Unable to find BAUHN APPS-0423 in the Bluetooth device list when pairing	<ul style="list-style-type: none"><li>• Ensure you have paired the speaker with your Bluetooth enabled device.</li><li>• Ensure the Bluetooth function is activated on your Bluetooth enabled device.</li><li>• Press and hold the  button on the remote for 3 seconds to disconnect the existing paired device.</li></ul>
General sound issues	<ul style="list-style-type: none"><li>• Make sure the speaker is set to the correct mode; make sure the volume knob is not set to off.</li><li>• Turn the volume knob to increase the volume.</li><li>• Press the VOL + button on the remote to increase the volume.</li><li>• Bluetooth mode: make sure the speaker is paired to the correct Bluetooth device.</li><li>• AUX mode: ensure you have connected the audio cable to the AUX port of the speaker, and the external device's volume is on.</li></ul>



# Specifications

AC Adaptor - input	AC 100-240V, 50/60Hz
AC Adaptor - output	DC 15V 3A
Power Consumption	Max. 45W
Sealed Lead Acid Battery	12V, 5Ah
Speaker	2 x 20W
Audio output power	40W RMS
Bluetooth® pairing name	BAUHN APPS-0423
Bluetooth® pairing operation range	> 8m
Dimensions (W x H x D)	320mm x 710mm x 320mm
Net weight	11kg
Gross weight	12.80kg

The Bluetooth® word mark and logos are registered trademarks owned by Bluetooth SIG, Inc., and any use of such marks by Hands (IP) Holdings Pty Ltd is under license. Other trademarks and trade names are those of their respective owners.

## For Technical Support:

[tempo.org/support](http://tempo.org/support)

Distributed by Tempo (Aust) Pty Ltd,

PO Box 132, Frenchs Forest NSW 1640



# Compliance and Responsible Disposal



## Packaging

The packaging of your product has been selected from environmentally friendly materials and can usually be recycled. Please ensure these are disposed of correctly. Plastic wrapping can be a suffocation hazard for babies and young children, please ensure all packaging materials are out of reach and are safely disposed of. Please recycle these materials rather than throwing them away.

## Product

At the end of its working life, do not throw this product out with your household rubbish. An environmentally friendly method of disposal will ensure that valuable raw materials can be recycled. Electrical and electronic items contain materials and substances which, if handled or disposed of incorrectly, could potentially be hazardous to the environment and human health.

## Compliance

This product complies with the Australian Safety Standard AS/NZS 62368.1 to ensure the safety of the product.



# BAUHN®

## Warranty Information

The product is guaranteed to be free from defects in workmanship and parts for a period of 12 months from the date of purchase. Defects that occur within this warranty period, under normal use and care, will be repaired, replaced or refunded at our discretion, solely at our option with no charge for parts and labour. The benefits conferred by this warranty are in addition to all rights and remedies in respect of the product that the consumer has under the Competition and Consumer Act 2010 and similar state and territory laws.

Our goods come with guarantees that cannot be excluded under the Australian Consumer Law. You are entitled to a replacement or refund for a major failure and to compensation for any other reasonably foreseeable loss or damage. You are also entitled to have the goods repaired or replaced if the goods fail to be of acceptable quality and the failure does not amount to a major failure.



# **BAUHN<sup>®</sup>**

## **Repair and Refurbished Goods or Parts Notice**

Unfortunately, sometimes faulty products are manufactured, which need to be returned to the supplier for repair.

Please be aware that if your product is capable of retaining user-generated data (such as files stored on a computer hard drive, telephone numbers stored on a mobile telephone, songs stored on a portable media player, games saved on a games console or files stored on a USB memory stick) during the process of repair, some or all of your stored data may be lost. We recommend you save this data elsewhere prior to sending the product for repair.

You should also be aware that rather than repairing goods, we may replace them with refurbished goods of the same type or use refurbished parts in the repair process.

Please be assured though, refurbished parts or replacements are only used where they meet ALDI's stringent quality specifications.

If at any time you feel your repair is being handled unsatisfactorily, you may escalate your complaint. Please telephone us on 1300 002 534 or write to us at:

Tempo (Aust) Pty Ltd ABN 70 106 100 252  
PO Box 132, Frenchs Forest, 1640 NSW, Australia  
Telephone: 1300 002 534 (Aust) - Fax: (02) 8977 3765  
Tempo Help Desk: 1300 002 534 (Aust)  
(Operating Hours: Mon-Fri 8:30am-6pm; Sat 9am-6pm AEST)  
Email: [tempo.org/support](mailto:tempo.org/support)

## Online support

Visit [bauhn.com.au](http://bauhn.com.au) for the latest User Manual for information on the updated features.

## Warranty returns

Should you for any reason need to return this product for a warranty claim, make sure to include all accessories with the product.

## Product does not work?

If you encounter problems with this product, or if it fails to perform to your expectations, please contact our After Sales Support Centre on 1300 002 534.

ALDI guarantees that our products are developed to our stringent quality specifications. If you are not entirely satisfied with this product, please return it to your nearest ALDI store within 60 days from the date of purchase for a full refund or replacement, or take advantage of our after sales support by calling the supplier's Customer Service Hotline.



### AFTER SALES SUPPORT



 AUS 1300 002 534

 [tempo.org/support](http://tempo.org/support)

MODEL: APPS-0423 PRODUCT CODE: 710656 04/2023

# 1

YEAR WARRANTY