

1 Have you got everything?

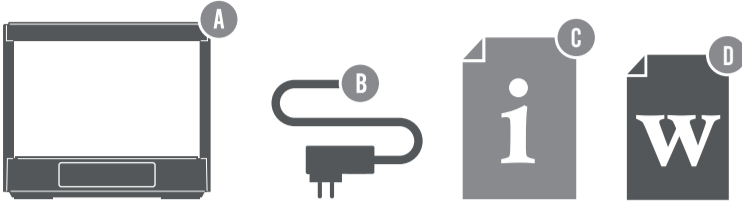

Unpack the box (be gentle) and make sure all of these items are there:

- A. Dual Wireless Charging Clock C. User Guide
B. Power Adaptor D. Warranty Certificate

Product Overview

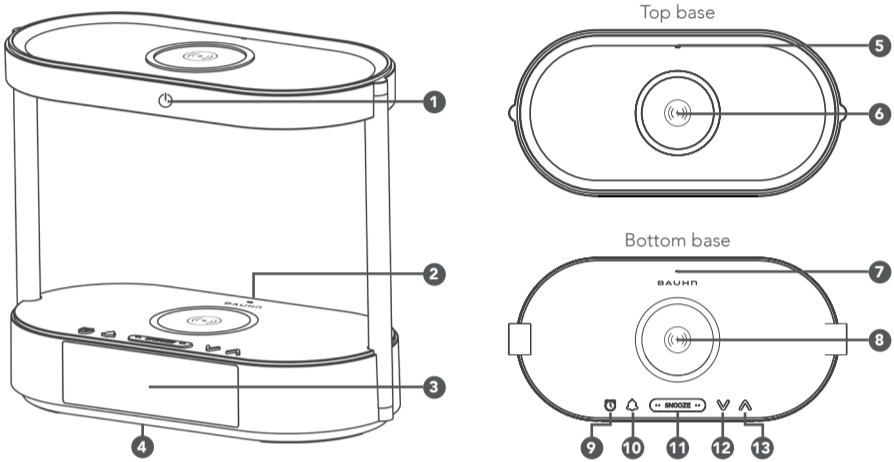

1. : press to turn the light on/off and adjust the brightness
2. **DC PORT**: plug in the supplied adaptor to the DC port and the other end to a power socket with a power source to power on the unit
3. **LCD DISPLAY SCREEN**
4. **Clock Backup Battery**: use a screwdriver to remove the screw and insert a CR2032 battery (not included).
5. **5W WIRELESS CHARGER LED INDICATOR**
6. **5W WIRELESS CHARGING PAD**
7. **10W WIRELESS CHARGER LED INDICATOR**
8. **10W WIRELESS CHARGING PAD**
9. : press to enter clock and alarm settings
10. : press to display the alarms
11. **SNOOZE**: press to enter snooze mode. In Clock mode, press to adjust the LCD display brightness. Press and hold to turn alarms on/off
12. : in Clock setting mode, press to set the time and alarm. When alarm is ringing, press to turn off the alarm
13. : in Clock setting mode, press to set the time, alarm, change between 12 / 24 hour display mode. When alarm is ringing, press to turn off the alarm

3 Operation

Connect the supplied power adaptor to the DC port on the unit and the other end to a wall plug. The LCD display screen will light up and a beep sound will be heard.

To set the time, press the button. The hour on the LCD display screen will flash. Use the / buttons to set the hour. Press the button again and the minutes on the LCD display screen will flash. Use the / buttons to set the minutes. Press the button again to store the time setting (the time setting will automatically exit after 30 seconds of no operation). Once the time is set, press the button to switch between 12 hour/24 hour display mode.

To set the 1st alarm, press the button to enter alarm mode. Press the button and the hour on the LCD display screen will flash. Use the / buttons to set the hour. Press the button again and the minutes on the LCD display screen will flash. Use the / buttons to set the minutes. Press the button again to set the snooze timer (5/10/15/20/25/30 minutes). Press the button to store the alarm setting (the alarm setting will automatically exit after 30 seconds of no operation).

To set the 2nd alarm, repeat the above steps.

To turn both alarms on/off, press and hold the SNOOZE button. It will turn on/off the 1st alarm, 2nd alarm and both alarms.

When an alarm rings, press the SNOOZE button to enter snooze mode. Press the SNOOZE button again to cancel snooze. When an alarm rings, press the / / / buttons turn off the alarm. The alarm will automatically stop ringing after 1 minute of no operation.

Press the SNOOZE button to adjust the brightness of the LCD display screen (high/medium/low/off).

Press the button to adjust the light brightness (low/medium/high/off).

To use the dual wireless chargers, place your smart phone facing up on the 5W/10W wireless charging pads. The 5W/10W wireless charging LED indicator will light up red when charging. If the smart phone doesn't start charging, adjust the position and/or remove your smart phone case. Also ensure that there are no metal or other objects between the smart phone and the wireless charging pad.

Notes:

The wireless charging function works only on wireless charging compatible smart phones.

Note: this unit uses a button or coin cell battery as backup (not included) as a backup system. Using a screwdriver, remove the battery compartment cover on the underside of the unit and insert the battery, ensuring the positive (+) is facing up.

When replacing the battery, do not disconnect the power adaptor otherwise the clock/alarm settings will be lost.

Your new product is ready to enjoy!

Well done, you made it.

Now sit back and relax... your new product is automatically covered by a 1-year warranty. How nice!



Troubleshooting

Wireless chargers not working

- Check that your smart phone supports wireless charging.
- Adjust the position of your smart phone to the centre of the wireless charging pad.
- Remove the smart phone case.
- Check and remove any metal or other objects between the mobile phone and wireless charging pad (the LED indicator will flash red).

LCD display screen not showing

- Check that the power adaptor is plugged into the DC port and the other end to a power socket with a power source.
- Press the SNOOZE button to check whether the screen is on lowest brightness setting.

Specifications



Power adaptor input	AC 100-240V, 50/60Hz 0.8A Max.
Power adaptor output	12VDC, 2.5A
Power consumption	30W
Top base wireless charging	5W
Bottom base wireless charging	10W
Dimensions (W x H x D)	225 x 191 x 111 mm
Weight	1031g (approx.)



Give us a call

What? You mean this User Guide didn't have ALL the answers? Speak to us!
 We'd love to help you get up and running as quickly as possible.
 Call our **After Sales Support** on **1300 002 534**.
 Operating hours: Monday-Friday, 8:30am-6pm; Saturday, 9am-6pm AEST

General Safety Warnings

For the safety of yourself and others, follow all instructions and take notice of all the warnings. When adhered to, these safety precautions can reduce the risk of fire, electric shock and injury.

This product complies with Australian Safety standard AS/NZS 62368.1 to ensure the safety of the product.



The RCM is a visible indication of a product's compliance with all applicable ACMA regulatory arrangements, including all technical and record-keeping requirements.

IMPORTANT

Plastic wrapping can be a suffocation hazard for babies and young children, so ensure all packaging materials are out of their reach.

To prevent environmental factors (dampness, dust, food, liquid etc.) harming the power bank, only use it in a well-ventilated, clean and dry environment, away from excessive heat or moisture.

Keep the product away from direct sunlight or heat sources.

In case of damage, do not disassemble, repair or modify the product yourself. Contact After Sales Support for advice on repair or replacement, or refer servicing to qualified personnel only.

This product is not intended for use by persons (including children) with reduced physical, sensory or mental capabilities, or lack of experience and knowledge, unless they have been given supervision or instruction concerning use of the product by a person responsible for their safety.

Children should be supervised to ensure they do not play with the product.

This product is not suitable for use in locations where children are likely to be present.

Do not put any object on top of the product

Do not place or store appliance where it can fall or be pulled into a bath or sink.

Do not place the product into water or any other liquids.

Do not expose the product to microwaves.

Do not place speakers too close to ears. Damage may occur to ear drums, especially in young children.

Do not dispose the battery into a fire or hot oven, and mechanically crush or cut the battery as this can lead to an explosion.

Do not place the product in a high temperature surrounding environment that can result in an explosion or the leakage of flammable liquid/gas.

Do not use the product at a low air pressure environment at high altitude as battery subjected to low air pressure can result in an explosion or the leakage of flammable liquid/gas.

Clean using a dry cloth only - do not use water or chemicals.

Keep the product away from oils, chemicals or any other organic liquids.

Use this appliance only for its intended purpose as described in this guide.

Responsible disposal of the packaging

The packaging of your product has been selected from environmentally friendly materials and can usually be recycled. Please ensure these are disposed of correctly. Plastic wrapping can be a suffocation hazard for babies and young children, please ensure all packaging materials are out of reach and are safely disposed of. Please recycle these materials rather than throwing them away.

Responsible disposal of the product

At the end of its working life, do not throw this product out with your household rubbish. An environmentally friendly method of disposal will ensure that valuable raw materials can be recycled. Electrical and electronic items contain materials and substances which, if handled or disposed of incorrectly, could potentially be hazardous to the environment and human health.



WARNING!

Keep batteries out of reach of children. Swallowing may lead to serious injury or death in as little as 2 hours due to internal burns.

If swallowed, immediately call the 24-hour Poisons Information Centre on 13 11 26 for fast expert advice. Dispose of used batteries immediately.

This product has been designed so that the coin/button cell battery is not accessible to young children, as the battery compartment cover is secured with a screw or mechanical fastener. Always ensure that the compartment is secured before use.



WARNING: Uses button or coin cell battery as backup (not included). Hazardous if swallowed.

WARNING

Batteries must not be exposed to sources of excessive heat such as direct sunlight.